

RADIUS MAX LOAD

Note: maximum weight load on bottom Spikes (spikes closest to the floor) should not exceed 400kg

Equipment situated right on top of corner pillars

max load 180 kg (397lb)

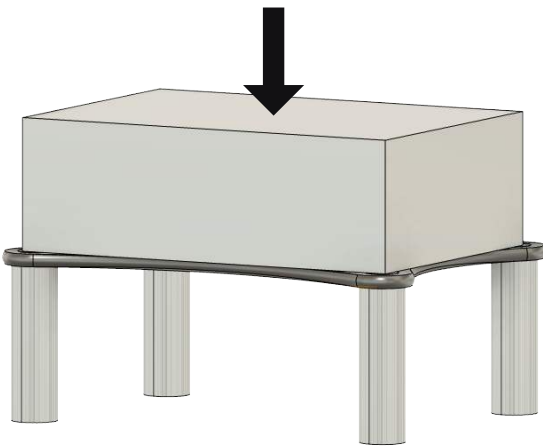

Equipment situated 10 cm (4 in) from corner pillars

max load 80 kg (176 lb)

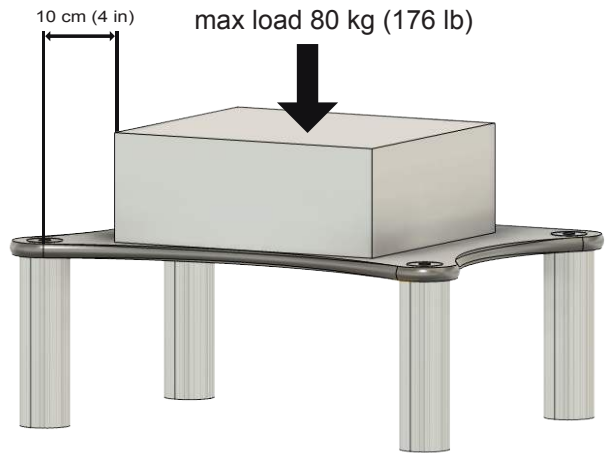

Equipment situated 20 cm (8 in) from corner pillars

max load 60 kg (132lb)

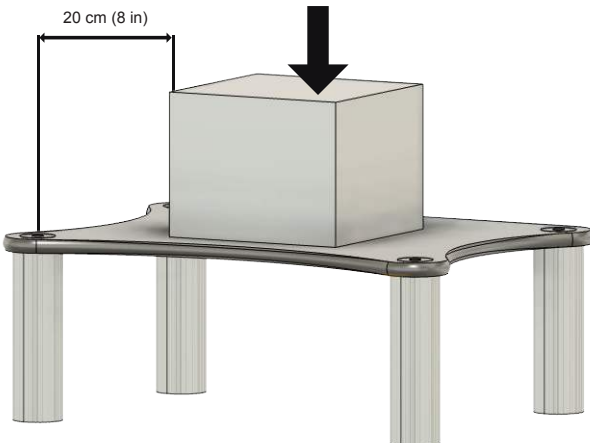

Equipment situated on top of double shelf for increased max load

max load 120 kg (164lb)

